

# FRAC Harness<sup>®</sup>

Installation Manual

For select **2014 – 2019** Model Year Toyota Vehicles

Version 2052720

Copyright © 2020 LG Technology LLC, All Rights Reserved

If you have any questions about the installation or have suggestions that you feel would make the instructions clearer, please let us know! You can contact TundraTex on the Tundras.com forum or by e-mail at [TundraTex@FRACv2.com](mailto:TundraTex@FRACv2.com).

## Introduction

Thank You for being a FRAC Harness customer. The FRAC Harness was designed to be mostly “plug and play” for ease of installation, however some installation skills are required. If you have installation questions, search for FRAC Harness on Tundras.com or YouTube for additional information. **Please review and understand all instructions before beginning the installation.** It will save you time and make your installation easier.

The FRAC Harness Kit includes the following:

- One FRAC Harness
- One Front Cam Power Wire Connector
- One Vehicle In Motion (VIM) Switch – not included with Non-Nav FRAC Harness kits
- One Cam Select Switch
- Switch Bezel for each Switch – Not needed for 1794, Platinum, or some Limited models.

**A camera is not provided. It must be purchased separately.**

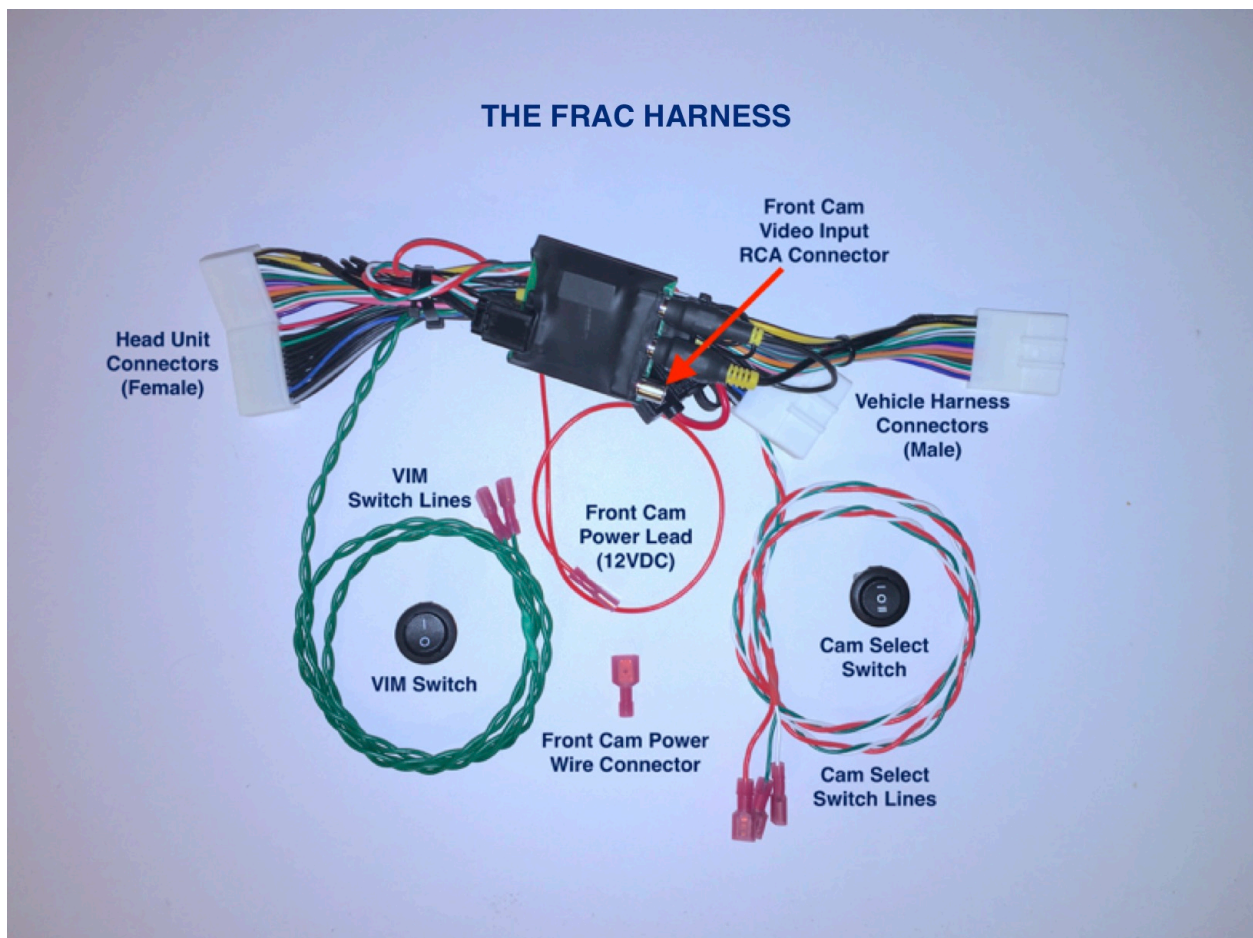

**Figure 1: FRAC Harness Kit Components**

**IMPORTANT NOTE:** The FRAC Harness is pre-assembled and consists of a number of wires and components. To avoid potential damage to the harness, **DO NOT remove the plastic cable ties.**

## Instructions

Before installing you may wish to view an installation video at [www.FRACHarness.com](http://www.FRACHarness.com) or on YouTube at: <https://www.youtube.com/TundraTex>.

1. Install a Front Camera of your choice (not included in FRAC Harness kit). Ensure the camera ground wire is firmly connected to desired ground location in engine compartment. Route camera video and power lines through the firewall and to the rear of the Entune Head Unit. Routing through passenger side firewall grommet is recommended.
2. Ensure vehicle ignition power is off (Key off or removed).
3. Remove Head Unit from the dash and rest it (upside-down) on the dash. (Use a towel or soft cloth to protect dash). Referring to the figure 2 below, locate J135 (28 Pin Connector) and J136 (24 Pin Connector) and disconnect them from the Head Unit.

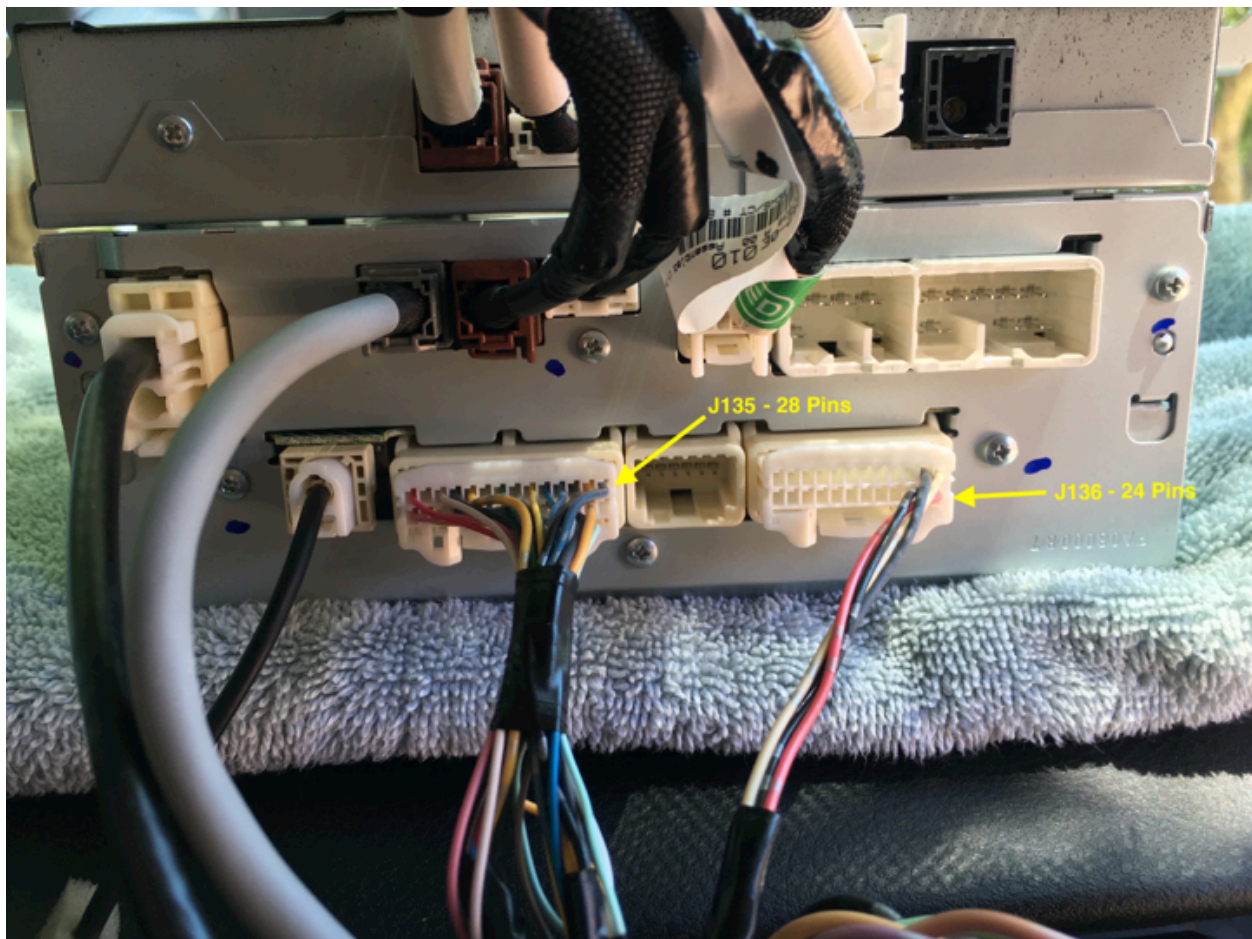

**Figure 2: Head Unit Connectors (Head Unit pictured upside down)**

4. Plug the J135 and J136 connectors removed in step 3 into the mating FRAC Harness Male Connectors.
5. Plug the FRAC Harness Head Unit Connectors into the Matching Head Unit Connectors.
6. Connect the video line from front camera to the FRAC Harness Front Cam Video Input RCA Connector.
7. Attach (Crimp or Solder) the provided spade power connector (Male) to the Front Camera power wire that was routed from the engine bay. Plug the front Camera Power line into the FRAC Harness Front

Cam Power Lead connector (Female spade connector). Once connected, wrap connection with tape or Shrink Tube to further secure the connection.

**NOTE:**

**If you are using the included switches for your installation, continue with step 8. If you are utilizing a Switch-Pros panel, skip steps 8-12 and refer to page 5 for alternate wiring information.**

8. Your FRAC Harness includes a Green 2-wire VIM switch line. If you don't want or need the VIM function, these wires can be soldered together and tucked behind the dash. If you want to use the VIM function connect both the VIM switch lines to the 2-position VIM Switch. The green VIM switch lines can be connected to either switch terminal.

9. Route the Cam Select switch lines and the VIM switch lines to the desired locations.

**VIM OPERATION NOTES**

**The FRAC VIM switch should be left in the "On" or "1" position for normal operation.** The VIM Switch Enables all Head Unit Function at any time. It does not affect the Camera Operations. If your passenger wishes to enable Nav functions while in motion, turning the VIM switch off to the "0" position will do this. When the VIM switch is off, the vehicle icon on the GPS moving map display may stop moving or move erratically. This is normal if VIM is off while moving. Once the desired Nav entries are made and the VIM switch is returned to the "on" position, the GPS should start updating the position icon within approximately 10 seconds.

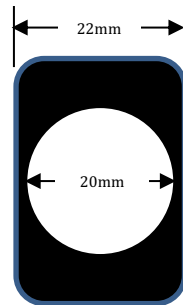

**Figure 3: Alternate switch location for 1794, Platinum and some Limited models.**

10. For vehicles with blank factory switch covers, remove the desired covers and route the switch wires from behind the panel, through the empty switch holes.

11. For 1794, Platinum, and some Limited models, there are no blank switch covers available. A suggested alternate location for the switches is shown in Figure 3. If switches are installed here, there may be insufficient clearance for the included spade terminals to fit. The switch harness wires may need to be soldered directly to the switch lugs.

NOTE: For applicable vehicle models, blank switch bezels are included with your kit. The bezels provide a convenient way to install the camera select switch and the VIM switch in blank switch locations. The FRAC Harness switches are designed to fit snugly in a 20mm hole. A metric progressive or step drill bit is highly recommended for drilling this hole. The switch bezel is 22mm wide so care must be taken to center the hole for proper installation.



**\*\*\* VERY IMPORTANT NEXT STEP \*\*\***

**The RED Cam Select switch wire MUST BE CONNECTED TO THE CENTER  
TERMINAL OF THE CAM SELECT SWITCH**

12. Connect the Cam Select switch lines to the 3-position Cam Select Switch As follows:

- White Wire to the Top Terminal (behind the - position)
- **Red Wire to CENTER terminal. (behind the 0 position)**
- Blue Wire to the Bottom Terminal (behind the = position)

13. Wiring installation is now complete. Before re-installing the Head Unit, test the FRAC Harness function. Turn the ignition to "on" to provide Head Unit Power. Use the Cam Select switch to select each of the cameras. Verify that the proper video is displayed for each switch position. Also verify that moving the gear selector to the Reverse (R) position activates the rear camera video regardless of Cam Select switch position. **Note:** In some cases, the front camera video will briefly appear on the Head Unit display after switching out of the rear-view mode or when moving the shifter out of Reverse. This can happen due to a slight difference in timing between Head Unit and FRAC circuit switching speeds. This is normal operation.

14. Turn off ignition and reinstall the Head Unit into the dash, carefully ensuring that the harnesses behind the Head Unit are not pinched or twisted.

15. Re-install all panels that were removed during the installation, and the installation is complete.

## Optional FRAC Harness Installation with a Switch-Pro Panel Power System

The Switch-Pro SP-8100 is a panel power system that provides eight user-reprogrammable switches. It provides an alternative method to control vehicle accessories and can be used with the FRAC Harness. The steps provided below are for reference only and are based on information available from the Switch-Pros website. Before proceeding you should ensure the accuracy of the information below and of your installation. If you are unsure of how the Switch-Pro system works or how it should be connected, you should not proceed before contacting the Switch-Pro manufacturer or other qualified installation professionals for assistance and clarification.

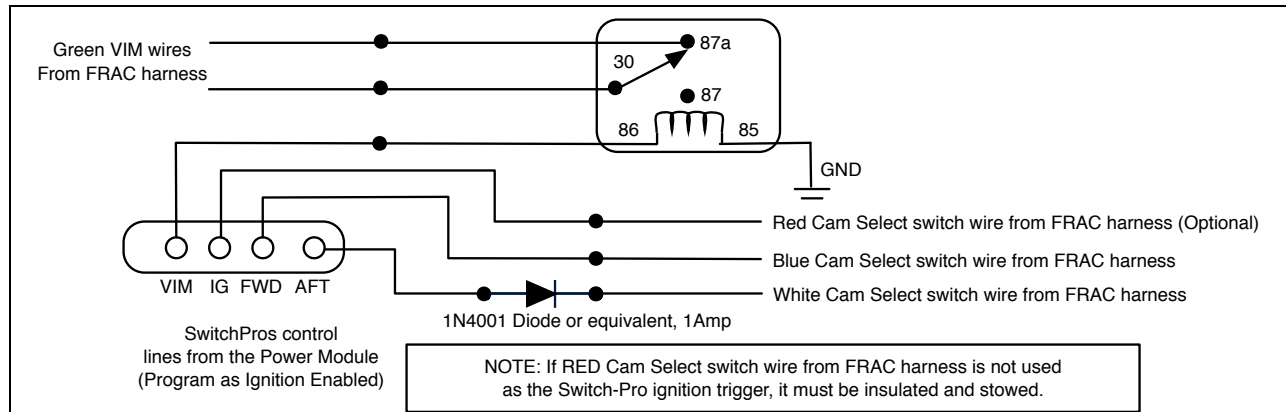

If you wish to control the VIM enable function with your Switch-Pro panel, you must utilize a standard 12V, 5-Pin (SPDT) automotive relay as shown. Connect the two green VIM switch lines to the relay pins 30 and 87a. Either VIM line may be connected to either of these two relay pins.

Connect the Switch-Pro output circuit wire desired for VIM select to pin 86 of the relay. Connect pin 85 of the relay to vehicle ground.

Connect the FRAC Harness Blue camera select wire to the desired Switch-Pro output circuit wire for the Forward camera selection.

Install a 1 Amp diode into the White FRAC Harness Cam select switch wire, between the FRAC Harness and the desired Switch-Pro output circuit wire for the Aft camera selection, as shown in the diagram above. This prevents FRAC Harness voltage from feeding back into the Switch-Pro unit. **FAILURE TO PROPERLY INSTALL A BLOCKING DIODE MAY RESULT IN DAMAGE TO YOUR SWITCH-PRO SYSTEM.**

The Red wire in the FRAC Harness cam select switch lines is powered with 12 Volts whenever the vehicle ignition is on. This wire may be used as your Switch-Pro ignition trigger. **IF IT IS NOT USED TO TRIGGER YOUR SWITCH-PRO SYSTEM, THIS WIRE MUST BE INSULATED AND STOWED PROPERLY TO AVOID CONTACT WITH THE VEHICLE GROUND OR OTHER WIRES. FAILURE TO DO SO COULD RESULT IN A SHORT CIRCUIT AND POSSIBLE DAMAGE TO VEHICLE SYSTEMS, THE SWITCH-PRO UNIT, OR THE FRAC HARNESS.**

Since individual Switch-Pro switches are used to select the desired camera, it is possible that both the forward and aft camera could be selected at the same time. In that case, the rear view will be displayed.